

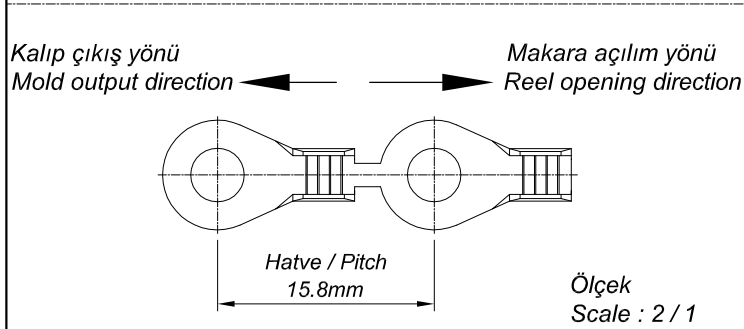

Bu çizim MESA OTO ELEKTRİK LTD.ŞTİ'nin malıdır. Şirket Yetkililerinin izni olmaksızın kopya edilemez, üzerinde değişiklik yapılamaz.
This Drawing MESA AUTO ELECTRIC LTD 's are property. Can not be copied without the consent of the company authorized, any changes can be made.

PARÇA KODU PART CODE	PARÇA ADI PART NAME	s ÖLÇÜSÜ (KALINLIK) s MEASURE (THICKNESS)	Malzeme Material	Kaplama / Coating		
				SN	AG	Nİ
TŞB 2559 RP	TOPRAKLAMA KLEMENSİ K.A. Ø3.9 =RP=	-----	(CuZn30) Pirinç / Brass	-	-	-
TŞB 2559 RPK	TOPRAKLAMA KLEMENSİ K.A. Ø3.9 =RPK=	-----	(CuZn30) Pirinç + Kalay / Brass + Sn	+	-	-

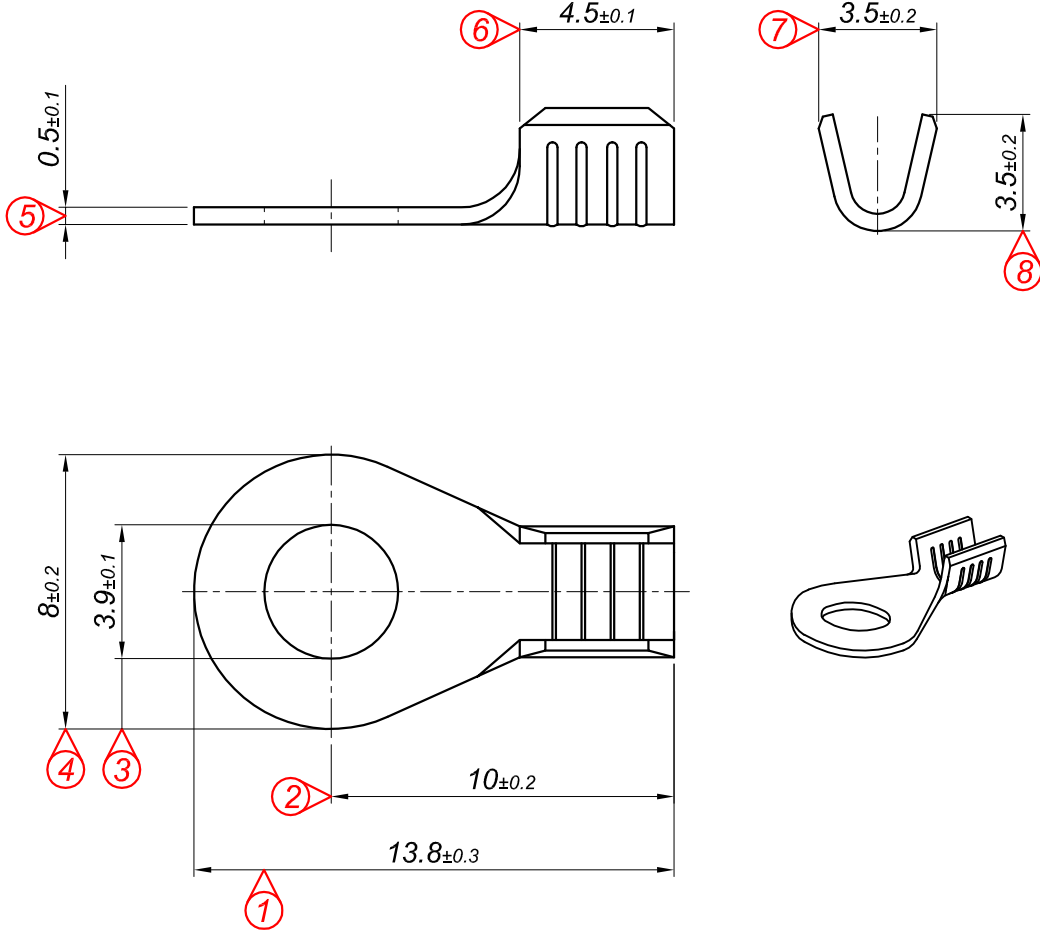

Kablo Kesiti
Wire Section : $0.50 - 1 \text{ mm}^2$

Resim üzerinden ölçü almayınız
do not measure on drawing

Tarih / Date	22.02.2019	İmza / Signature	Ölçek / Scale			
Çizen / Desing	M.Yağcı					
Onay / Approval	S.Gölcük		5 / 1	No	Değişiklik / Revision	Tarih/Date
	Parça Adı: Part Name	TOPRAKLAMA KLEMENSİ KÜÇÜK AYAK Ø3.9			Parça Kodu: Part Code	TŞB 2559